

## Positive Displacement Rotary Lobe Pumps

SPECIFICATIONS	US	Metric
Rated Capacity:	0-1,330 gpm	0-302 m <sup>3</sup> /h
Displacement (per 100 revolutions):	266 gal (US)	1,003 L
Working Pressure:	125 psi	8.6 bar
Max. Pressure:	150 psi	10.3 bar
Starting Torque:	3,857 in lbf	436 N m
Rated Speed:	0-500 RPM	0-500 RPM
Shaft Diameter:	2.4"	60 mm
Flange Connection Class:	ANSI 16.5-150#	DN - PN 10
Flange Connection Size:	ANSI 8"	DN 200
Weight:	815 lbs	370 kg
Solids Handling		
Spherical Compressible	3"	76 mm
Spherical Hard*	1/8"	3 mm

\* Larger hard solids will pass through but may cause damage.

MODEL >	SL266d	CL266d	DL266d
Service	Sludge, Mud and Slurries*	Chemical/Corrosive	Oil, Gas & Abrasives
<b>WETTED PARTS</b>			
<b>Rotary Lobes</b>			
Elastomer	NBR Opt. HNBR, FKM, EPDM or Eng. Rec.	FKM or HNBR Opt. NBR, EPDM or Eng. Rec.	FKM or HNBR Opt. NBR, EPDM or Eng. Rec.
Lobe Profile	Helix	Helix	Helix
Number of lobe wings	4	4	4
Core	Carbon Steel	Carbon Steel	Carbon Steel
<b>Sealing Elastomers</b>			
O-rings	FKM	FKM or Engineer Recommendation	FKM or Engineer Recommendation
Lip seals	FKM or Engineer Recommendation	FKM or Engineer Recommendation	FKM or Engineer Recommendation
<b>Mechanical Seals</b>			
Mechanical Seal	Duronit Opt. Tungsten Carbide, Silicon Carbide, or Eng. Rec.	Silicon Carbide Opt. Tungsten Carbide or Engineer Rec.	Silicon Carbide Opt. Tungsten Carbide or Engineer Rec.
Seal Holders	Carbon Steel with Corrosion resistant coating	Stainless Steel Type 316	Duplex Stainless Steel
<b>Wear Plates</b>	AR500 Steel (Brinell 500)	Stainless Steel Type 316	Duplex Stainless Steel
<b>Housing Segments</b>	ASTM A48 Grey Iron rust primed	Duplex Stainless Steel	Duplex Stainless Steel
<b>Flange Ring</b>	ASTM A36 Carbon Steel	Stainless Steel Type 316L	Duplex Stainless Steel
<b>Bolts</b>	Steel ASTM F568/ISO 898/1	Stainless Steel A2-A4	Duplex Stainless Steel A2-A4
<b>Bolts-Strain Bolt</b>	ASTM A574M-12.9 Geomet Plus Coated	Stainless Steel Type 316	Duplex Stainless Steel
<b>Pressure Disc</b>	Stainless Steel Type 316L	Stainless Steel Type 316L	Duplex Stainless Steel
<b>LIMITED EXPOSURE PARTS</b>			
<b>Quench /Seal Cooling Chamber</b>	ASTM A48 Grey Iron rust primed	ASTM A48 Grey Iron - SSPC-SP6 Sandblast/Paint Opt. Engineering Recommendation	ASTM A48 Grey Iron - SSPC-SP6 Sandblast/Paint with PTFE / Ceramic Teflon etched on face
<b>Pump Cover - Door/Ld Assembly</b>	ASTM A48 Grey Iron rust primed	ASTM A48 Grey Iron - SSPC-SP6 Sandblast/Paint Opt. Engineering Recommendation	ASTM A48 Grey Iron - SSPC-SP6 Sandblast/Paint Opt. Engineering Recommendation
<b>NON-WETTED PARTS</b>			
<b>Gears</b>	AGMA Class 9 SAE 1045 steel	AGMA Class 9 SAE 1045 steel	AGMA Class 9 SAE 1045 steel
<b>Gear Housing</b>	ASTM A48 Grey Iron rust primed	ASTM A48 Grey Iron - SSPC-SP6 Sandblast/Paint Opt. Engineering Recommendation	ASTM A48 Grey Iron - SSPC-SP6 Sandblast/Paint Opt. Engineering Recommendation
<b>Shaft</b>	AISI 4140 Alloy Steel	AISI 4140 Alloy Steel	AISI 4140 Alloy Steel

**NOTE:** A wide range of optional materials are available for each model. Above specs are for standard builds. Consult LobePro for further information.  
\*Consult Factory for application temperature above 80°C (175°F)

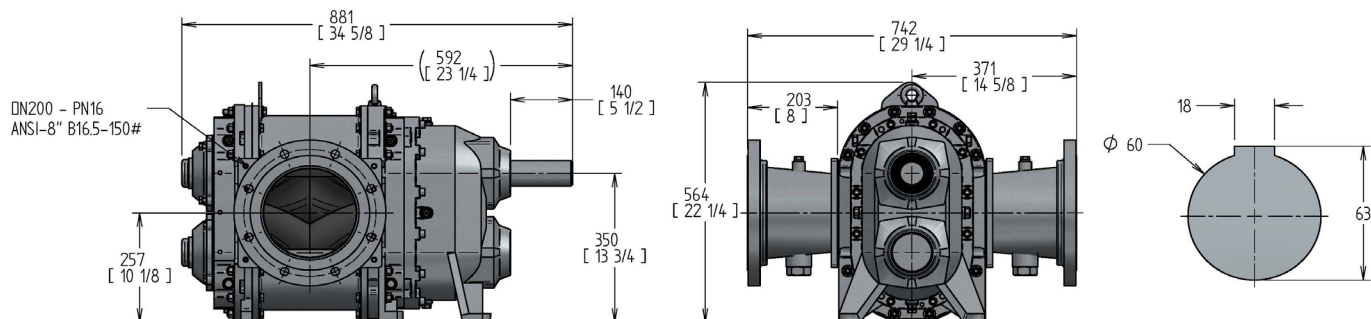

**Section 40-55**

5 October 2016

**L266d CURVES**

**Performance Curve - NBR Lobes\***  
 Based on 70°F (21°C) fresh water (1 cp) at Sea Level.  
 Output will increase as viscosity of the fluid increases from 1.

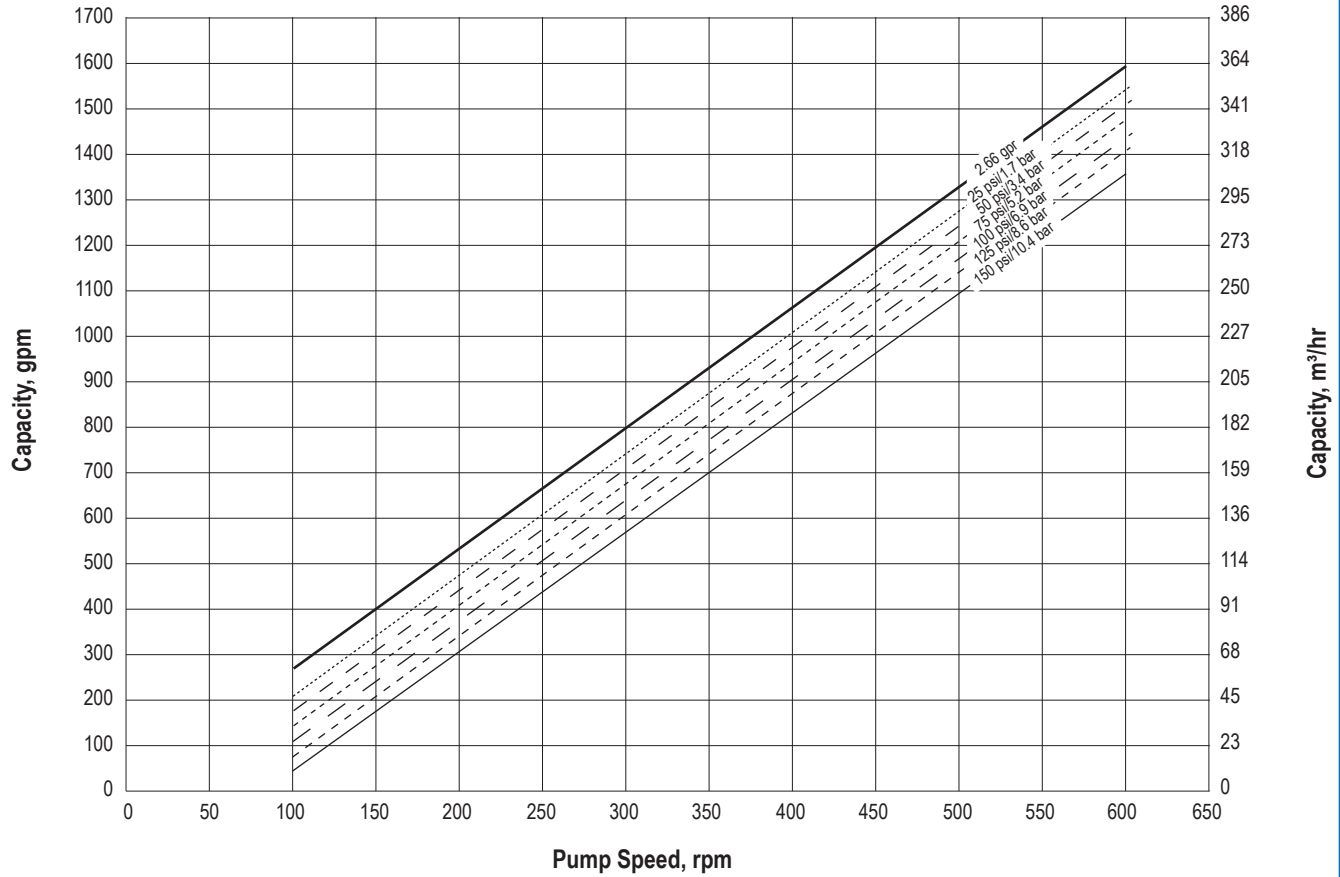

\*Note: Output from lobes coated with elastomers other than NBR maybe lower. Contact Engineering for further information.

**Horsepower Requirements**

